

# Alfem Telecom

## SUPPORT FOR SUSPENSION AND ANCHORING OF OPTICAL CABLE

### PERSPECTIVE MODELS



### SIDE VIEW

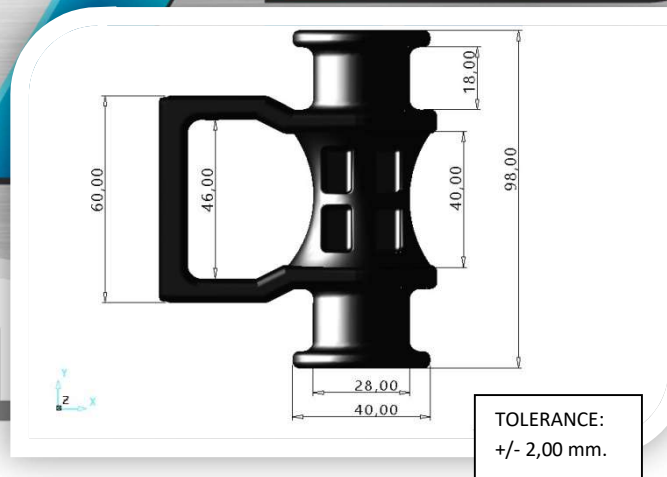

### ISSUE: TECHNICAL MANAGEMENT OF ALFEM TELECOM PRODUCTS

MARCH / 2018

ELABORATED: LUIS RICARDO COSTA

APPROVED: ANTONIO COSTA / FERNANDO RICARDO

VALIDATED:



# Alfem Telecom

## SUPPORT FOR OPTICAL CABLE SUPENTION AND ANCHORING

### APPLICATION:

Used for the passage of self-supporting aerial dielectric optical cables on the pole. Must be used between Anchor Sets. It can be used for stretcher hooks and anchor and dróp supports. It must be installed together with BAP CLAMP.

### MATERIAL:

PLASTIC PART - Ermo-Plastic NYLON 6 OR POM (POLYACETAL) in BLACK OR BLUE color, with ANTI-UV charge.

### FINISHING:

Both the plastic and metal parts must be uniform, free of burrs, cracks, cracks or other imperfections that affect their applications.

### PACKING:

Packed in PLASTIC BAGS with 20 units. It can be accommodated in CARDBOARD BOXES with up to 100 units. Packaging must be done in such a way as not to cause any physical damage during transport and storage. Packaging must bear labels described below.

### BRAND:

The SUSPENSION BRACKET shall have:

- 1º - Name/brand of the manufacturer IN HIGH RELIEF;
- 2º - Date of manufacture

The BOX must present:

- 1º - Label with the name of the Consumer Client;
- 2º - Label with invoice number.
- 3º - Label with quantity of SUPPORTS inside the box.

### MATERIAL CODE:

CODE 016-A – SUPPORT FOR SUSPENSION AND SUPPORT AND ANCHORING OF OPTICAL CABLE.

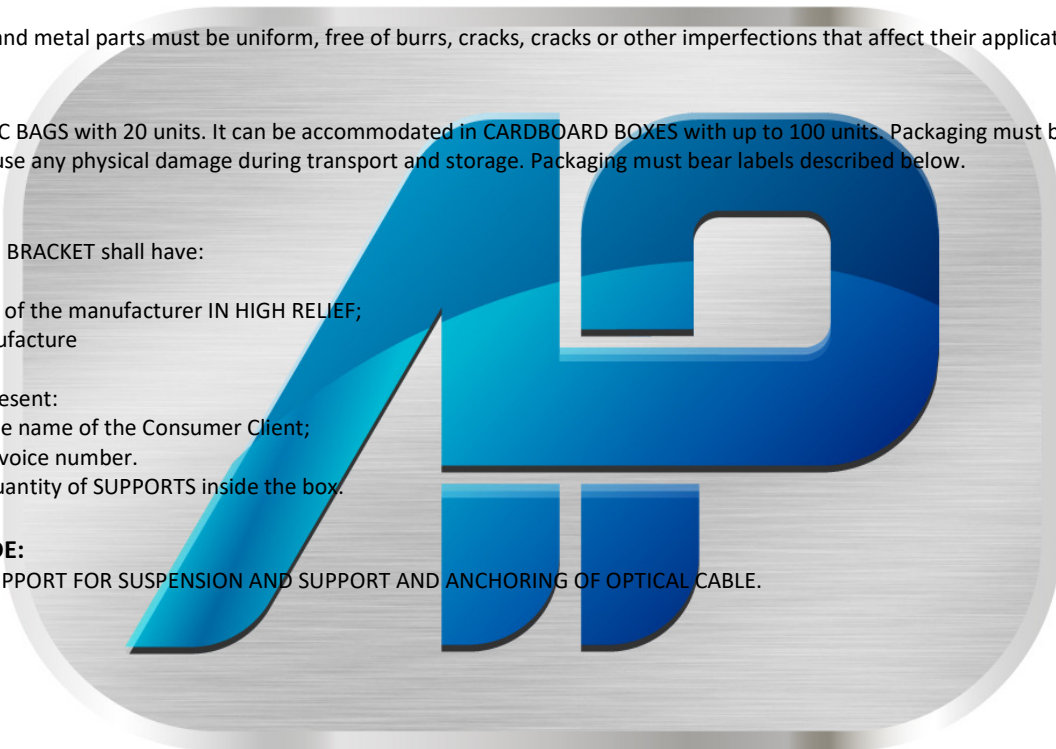

# ALFEM PLASTIC

### ISSUE: TECHNICAL MANAGEMENT OF ALFEM TELECOM PRODUCTS

MARCH / 2018	ELABORATED: LUIS RICARDO COSTA	 ALFEM PLASTIC
	APPROVED: ANTONIO COSTA / FERNANDO RICARDO	
	VALIDATED:	